

Pneumatic Products™



Internally Heated
Desiccant Dryers
DEA Series

Pneumatic Products™

Extraordinary Efficiency – By Design

DEA Series dryers stand apart from the ordinary. Everyone knows, heat rises. Our down flow drying process takes advantage of that principle. In regeneration mode, the stored heat of adsorption and equi-distant bed heating ensure consistent bed temperatures. Rising heat provides natural bed convection, to evacuate the water vapor. Operating at full-load, a mere 3% of purge gas assists this process. DEA Series dryers approach 97% efficiency, by design.

Annual Energy Savings

Average Air Demand		Regeneration Cost by Technology ¹		
flow	scfm	Typical Heatless Design Cost of 15% Purge	Typical Externally Heated Design Cost of 7% Purge	DEA Series With AMLOC [®] 3% Purge
100%	2,000	\$39,210	\$18,298	\$7,842
90	1,800	39,210	18,298	6,352
75	1,500	39,210	18,298	4,705
50	1,000	39,210	18,298	2,941
35	700	39,210	18,298	961
20	400	39,210	18,298	314

¹ Assumes 5 scfm per HP, 8760 hours of operation per year, 10 cents per kW/h

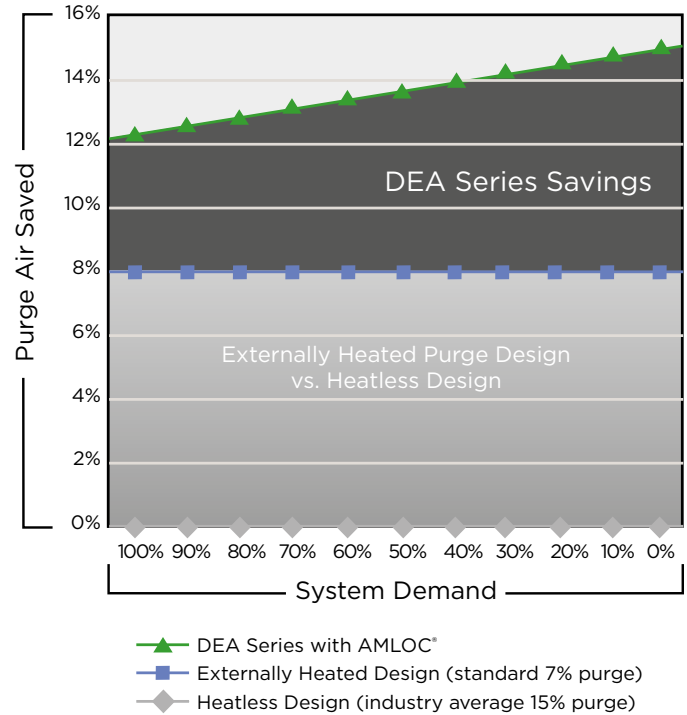

Since 1946, the world has turned to the Pneumatic Products brand for the quality and service demanded by the most critical of applications. Global leaders of industry require durable components that deliver unquestionable reliability. Our precision engineered components and designs deliver outstanding service life and operational longevity. Invest in our experience and gain annuities that will grow for years.

How It Works

Moist, filtered compressed air enters downflow drying Chamber 1 through valve (A). Water vapor is adsorbed onto the desiccant and dry compressed air exits through valve (B) where, abrasive desiccant dust is captured by a high-temperature afterfilter. In regeneration mode, balanced heat distribution in Chamber 2 comes from natural heat-of-adsorption and the Equi-distant heater tube system (C) to release the water vapor. A mere 2-3% of dry process air (D) directs the water vapor evacuation through valve (E) and a muffler. Once desorbed, the heater turns off and cool dry purge air continues to pass to cool the bed. Then, valve (E) closes and Chamber 2 is repressurized. No further energy will be consumed until AMLOC® determines the on-line bed is fully utilized. Whereupon, operations will switch and Chamber 1 will be regenerated.

AMLOC® governs this process with precision as the capacitance probes sense the dielectric strength water vapor imparts on the desiccant. Low moisture loads extend the drying cycle while eliminating energy use. Fewer flow reversals and minimal thermal stress yields longer desiccant and valve life. Serious performance, reliability and energy savings result as energy consumption mirrors plant air usage.

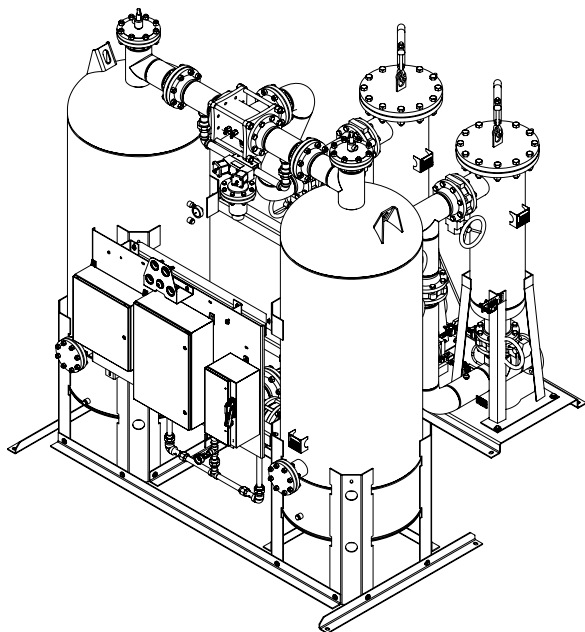

DEA Series Flow Diagram

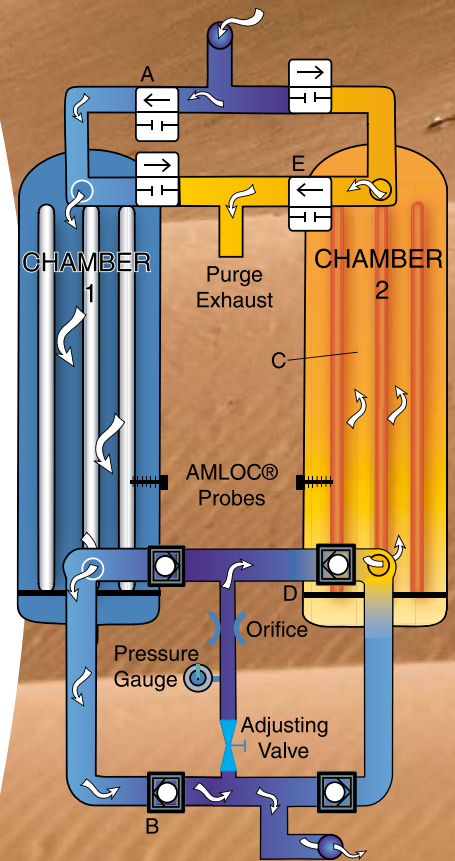

Pneumatic Products™

DEA Series - Key Product Features

Engineered Performance

Non-lubricated Select Series and/or Century Series valves.
The ULTIMATE in reliability



Heat Management

Cross section illustrates equi-distant Heater Tube design



AMLOC® Energy Optimizer

Synoptic indication of Process Phases

RS-485 connection providing MODBUS RTU communication or Ethernet connection providing MODBUS TCP communication available.
4 line X 80 character information center.



Sensory Perception

- AMLOC® Probe proven in over 25,000 installations.
- Lifetime Warranty. No calibration required.

Personnel Protection

Optional expanded metal personnel protection

Optional A/B PLC with Z-Purge

PLC controller with 4" color HMI is now available as an affordable, pre-engineered option. This units touch screen interface offers real-time, graphical monitoring of the dryers operation. Advanced communication includes RS-232/RS-485, ethernet and USB connections



**Model Shown with Optional Features*

Exclusive Feature Details

Process Quality Valves - Engineered Simplicity

Standard off-the-shelf valves under performed on critical air dryer applications so we engineered our own. Tested under adverse conditions without failure in excess of 500,000 cycles, our full port, air-operated Century Series poppet valves feature stainless steel internals. To protect against wear, a friction-free PTFE coating is applied to all wear surfaces. Corrosion resistant and non-lubricated, these valves were engineered to withstand elevated temperatures, clogging and erosion caused by abrasive desiccant dust. These are the best valves in the industry - period.

** Models 8200DEA and larger feature Century Series valves.*



SMarT ADC Control System

The SMarT ADC is an update to our time tested, user-friendly electronic synoptic controller for heatless dryer applications. The SMarT ADC builds upon the success of the legendary ADC control system adding new and innovative features.

The SMarT ADC Controller utilizes dual micro-processors to provide advanced communications and improved analog sensor support. The application processor provides the control functions and advanced communications options. The analog microprocessor performs the analog processing tasks including taking readings from various process sensors and communicating this data to the application processor. The application processor is a new microcontroller that has the built-in capability to communicate via Ethernet. This capability can be used to communicate over factory ethernet connections and the internet. This connection allows users to remotely monitor via the web interface their equipments performance, diagnostics, and status indicators. Additional communications compatibility is provided via the RS-485 connection allowing the controller to communicate with ModBus applications.



Automated Moisture Load Control (Amloc®):

Today's air system auditors know that it is rare to find a dryer that operates under full-load conditions. That is why AMLOC® is standard equipment on every DEA Series dryer we build. AMLOC® energy management systems continue to generate tens-of-thousands of dollars in energy saving annuities for industry leaders. Our exclusive ceramic coated, stainless steel capacitance probes sense the dielectric strength imparted upon the desiccant by the extracted water vapor. Capable of identifying an aging or fouled bed, the heating and purge cycles are managed with precision. AMLOC® reduces cycle frequency to extend component life, ensures consistent dew points, and averages <1% purge gas consumption. Lifetime probe warranty and never needs calibration.



Exclusive Feature Details Continued

PCC & PCS Series Filtration

Critical applications and hostile environments demand premium grade products. Global industry leaders rely on PCS & PCC Series filters for their unmatched quality, durability and reliability in tough applications. PPC's large flow filters meet the challenge and provide contaminant protection for the premium grade desiccants used in our dryers as well as contaminant sensitive applications. Power plants, paper mills, refineries, and petrochemical installations are a few examples of the challenging environments that rely on PPC filters for lasting protection.



Product Feature List

Filtration	
Piped Prefilter and Afterfilter Filtration	Standard
AMLOC® Energy Management System	
PTFE coated, stainless steel capacitance sensor, lifetime probe warranty, never needs calibration	Standard
Desiccant:	
Premium Grade Activated Alumina	Standard
Moisture Indicator	
Aquadex® Visual, Color Change	Standard
ADC Control System w/ AMLOC® Intelligence	
Energy Management System - Automatic Savings	Standard
Extended drying cycles - long component life	Standard
RS-485 port- communications capable	Standard
Operational History Log Stores 20 Events - Simplifies Trouble-Shooting	Standard
Synoptic display with active flow path illumination LEDs	Standard
Class 1, Groups C & D, Division II	Optional
PLC Control	
A/B Micro 800 Series PLC, 4" Color Touchscreen HMI, NEMA 4X Fiberglass Enclosure, RS-485 Modbus RTU, Ethernet, RS-232, USB	Optional
Information Center	
Back-lit LCD - Visual Clarity In Diverse Lighting Conditions	Standard
4 categories: Dryer Status, Service, History, Configuration	Standard
Warning & Alarm Lights	Standard
Alarm Protection Parameters:	
Alarm Failures: Depressurization Re-pressurization On-line Pressure, Thermocouple, Heater Over-Temperature	Standard
Warning: AMLOC® Failure, High Humidity	Standard
Service Reminders: Valves, Desiccant, Filters	Standard
Additional Optional Features	
Z-Purge - CL1-Div2 Hazardous locations	Optional
Tower personnel protection	Optional

Premium Desiccant:

The DEA utilizes a high performance three layer desiccant bed that consist of:



Top Layer Protective Activated Alumina



Middle Layer - Bulk drying Silica Gel



Bottom Layer - Polishing Molecular Sieve

Each desiccant selected and engineered to provide our most energy efficient desiccant drying solution.

Product Specifications

DRYER MODEL	INLET/ FLOW	HEATER QTY PER CHAMBER	KW PER CHAMBER	AVG KW PER DAY	DIMENSIONS ² INCHES			APPROX ² WEIGHT	INLET/OUTLET ² CONNECTIONS	MOUNTED FILTRATION	
	SCFM		480v	480v	H	W	D	LB	IN	PREFILTER	AFTERFILTER
8120DEA	330	9	7.4	97	120	65	52	1,725	1 1/2"NPT	PCS15001SU	PCS15001HT
8140DEA	410	12	10	130	121	66	52	2,050		PCS15001SU	PCS15001HT
8160DEA	538	15	12.4	162	121	68	55	2,475	2"NPT	PCS16001SU	PCS16001HT
8180DEA	687	18	14.9	195	121	76	55	2,625		PCS18001SU	PCS18001HT
8200DEA	867	21	17.3	227	123	77	55	3,125	3"FLG	PCS112001SU	PCS112001HT
8220DEA	1143	24	19.8	345	126	88	56	3,825		PCS112001SU	PCS112001HT
8240DEA	1269	30	24.8	476	127	88	80	4,510	4"FLG	PCC114003SU	PCC114003HT
8260DEA	1467	33	27.2	476	131	92	79	5,035		PCC118003SU	PCC118003HT
8280DEA	1761	39	32.2	563	131	98	82	5,335	4"FLG	PCC118003SU	PCC118003HT
8300DEA	2034	45	37.1	648	131	106	82	7,855		PCC124004SU	PCC124004HT
8360DEA	2900	51	51	820	138	117	96	10,250	6"FLG	PCC136003SU	PCC136003HT
8420DEA	4333	66	66	1060	143	133	100	13,925		PCC148004SU	PCC148004HT

¹ Performance data per CAGI Standard ADF 200 for Dual-Tower Regenerative Desiccant Compressed Air Dryer. Rating conditions are 100°F (37.8°C) inlet, 100 psig (6.9 bar) inlet pressure, 100% relative humidity, 100°F (37.8°C) ambient temperature.

² Dimensions, Weights & Inlet/Outlet Connections based on F-01 pre-piped filter options.

Consult factory for sizing assistance. Larger models available.

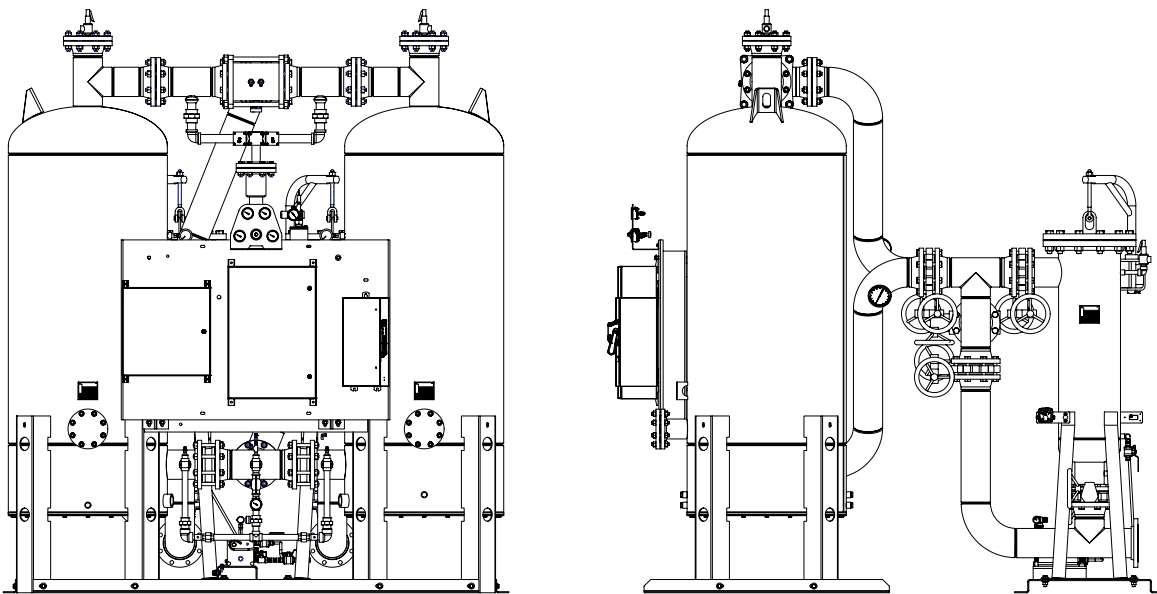

Internally Heated Desiccant Dryers

DEA Series

330 - 4,333 scfm

Design features, materials of construction and dimensional data, as described in this bulletin, are provided for your information only and should not be relied upon unless confirmed in writing.

Please contact your local sales representative for product availability in your region.

 **Pneumatic
Products**TM

Pneumatic Products Headquarters

4647 SW 40th Avenue
Ocala, Florida 34474-5788 U.S.A.

Tel.: (724) 745-1555

Fax: (724) 745-6040

pneumaticproducts.com